

R-FF1-N-K-DT Nylon frame fixing with collar hex head - zink flake

Universal frame fixing with collar and hex head, delta tone plated screw for many applications



Approvals and Reports

- ETA-12/0398
- UKTA-22/6344



Product information

Features and benefits

- Special zinc flake corrosion-resistant coating for anti-corrosion protection
- Collared plug for fixing of hard materials (eg. steel)
- Specially-formulated nylon allows best performance installation for use in all base material categories according to ETAG 020 (A, B, C, D)
- Internal plug geometry designed to fit the screw head
- Plug design ensures multi-axis expansion

Applications

- Door and window frames
- Garage doors
- Gates
- Industrial doors
- Facade (substructures made of wood and metal)
- Wall cabinets
- Satellite dishes
- Shelves
- Handrails
- Cable trays

Base materials

Approved for use in:

- Concrete \geq C12/15 (Use category A)
- Solid Brick (Use category B)
- Solid Sand-lime Brick (Use category B)
- Hollow Brick (Use category C)
- Hollow Sand-lime Brick (Use category C)
- Hollow Lightweight Concrete Block (Use category D)
- Aerated Concrete Block (Use category D)
- Cracked concrete \geq C12/15 (Use category A)

Installation guide

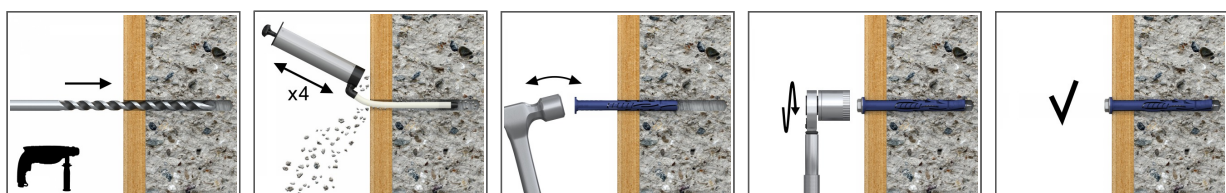

1. Drill a hole of required diameter and depth
2. With a hammer, lightly tap the plug through the fixture into hole until fixing depth is reached
3. Tighten the FF1 screw

Product information

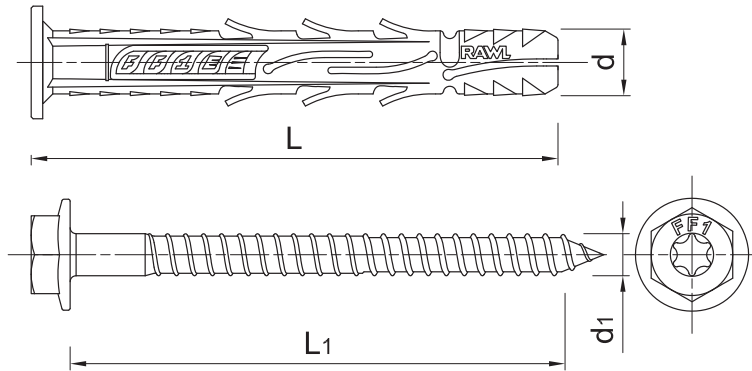

Size	Product Code	Plug		Screw		Fixture		
		Diameter	Length	Diameter	Length	Max. thickness		Hole diameter
		d	l	d ₁	L1	t _{fix} 50	t _{fix} 70	d _f
[mm]								
Ø10	R-FF1-N-10K080/DT	9.8	80	7	89	30	10	10
	R-FF1-N-10K100/DT	9.8	100	7	109	50	30	10
	R-FF1-N-10K120/DT	9.8	120	7	129	70	50	10
	R-FF1-N-10K140/DT	9.8	140	7	149	90	70	10
	R-FF1-N-10K160/DT	9.8	160	7	169	110	90	10
	R-FF1-N-10K200/DT	9.8	200	7	209	150	130	10
	R-FF1-N-10K240/DT	9.8	240	7	249	190	170	10
	R-FF1-N-10K300/DT	9.8	300	7	309	250	230	10

Installation data

Substrate			A, B, C	A, B, C	D
Hole diameter in substrate	d ₀	[mm]	10	10	10
Min. hole depth in substrate	h ₀	[mm]	60	80	80
Min. installation depth	h _{nom}	[mm]	50	70	70
Min. substrate thickness	h _{min}	[mm]	100	100	100
Min. spacing	s _{min}	[mm]	90	95	70
Min. edge distance	c _{min}	[mm]	80	80	70
Max. installation torque	T _{inst}	[Nm]	16	16	4.3
Wrench size	Sw	[mm]	13	13	13
Screw drive	-	[-]	T40	T40	T40
Diameter	d	[mm]	10	10	10
Effective embedment depth	h _{ef}	[mm]	50	70	70

Basic performance data

Performance data for single fixing without influence of edge distance and spacing

Substrate		Substrate														
		Concrete min. C12/15	Concrete min. C16/20	Solid brick min. 50MPa	Solid clay brick min 20MPa (eg Mz20/2.0)	Sand-lime brick min. 30MPa	Solid silicate brick min 20MPa (eg KS NF 20/2.0)	Perforated ceramic blocks min 15MPa (eg MEGA MAX)	Perforated ceramic blocks min 15MPa (eg Wienerberger Poro-	Sand-lime hollow block min. 20MPa	Lightweight concrete hollow block min 2.0MPa	Hollow brick min. 12MPa	Hollow brick min. 15MPa	Hollow clay block min. 7.5MPa	Autoclaved aerated concrete AAC 2	Autoclaved aerated concrete AAC 6
CHARACTERISTIC LOAD																
TENSION LOAD N_{Rk}																
Ø10, Effective embedment depth 50 mm	[kN]	1.20	2.00	-	-	-	-	-	-	-	-	-	-	-	-	-
Ø10, Effective embedment depth 70 mm	[kN]	6.00	8.50	-	-	-	-	-	-	-	-	-	-	-	-	-
SHEAR LOAD V_{Rk}																
Ø10, Effective embedment depth 50 mm	[kN]	5.40	5.40	-	-	-	-	-	-	-	-	-	-	-	-	-
Ø10, Effective embedment depth 70 mm	[kN]	5.40	5.40	-	-	-	-	-	-	-	-	-	-	-	-	-
TENSION AND SHEAR LOAD F_{Rk}																
Ø10, Effective embedment depth 70 mm	[kN]	-	-	5.00	-	-	-	1.50	1.50	3.50	0.90	0.90	0.75	0.75	0.40	0.90
Ø10, Effective embedment depth 50 mm	[kN]	-	-	-	-	1.50	-	-	-	-	-	-	-	-	-	-
DESIGN LOAD																
TENSION LOAD N_{Rd}																
Ø10, Effective embedment depth 50 mm	[kN]	0.67	1.11	-	-	-	-	-	-	-	-	-	-	-	-	-
Ø10, Effective embedment depth 70 mm	[kN]	4.28	4.72	-	-	-	-	-	-	-	-	-	-	-	-	-
SHEAR LOAD V_{Rd}																
Ø10, Effective embedment depth 50 mm	[kN]	3.35	3.35	-	-	-	-	-	-	-	-	-	-	-	-	-
Ø10, Effective embedment depth 70 mm	[kN]	3.35	3.35	-	-	-	-	-	-	-	-	-	-	-	-	-
TENSION AND SHEAR LOAD F_{Rd}																
Ø10, Effective embedment depth 70 mm	[kN]	-	-	2.00	-	-	-	0.60	0.60	1.40	0.36	0.36	0.30	0.30	0.20	0.45
Ø10, Effective embedment depth 50 mm	[kN]	-	-	-	-	0.60	-	-	-	-	-	-	-	-	-	-
RECOMMENDED LOAD																
TENSION LOAD N_{rec}																
Ø10, Effective embedment depth 50 mm	[kN]	0.48	0.79	-	-	-	-	-	-	-	-	-	-	-	-	-
Ø10, Effective embedment depth 70 mm	[kN]	3.06	3.37	-	-	-	-	-	-	-	-	-	-	-	-	-
SHEAR LOAD V_{rec}																
Ø10, Effective embedment depth 50 mm	[kN]	2.39	2.39	-	-	-	-	-	-	-	-	-	-	-	-	-
Ø10, Effective embedment depth 70 mm	[kN]	2.39	2.39	-	-	-	-	-	-	-	-	-	-	-	-	-
TENSION AND SHEAR LOAD F_{rec}																
Ø10, Effective embedment depth 70 mm	[kN]	-	-	1.43	-	-	-	0.43	0.43	1.00	0.26	0.26	0.21	0.21	0.14	0.32
Ø10, Effective embedment depth 50 mm	[kN]	-	-	-	-	0.43	-	-	-	-	-	-	-	-	-	-

Product commercial data

Product Code	Plug	Screw		Quantity [pcs]			Weight [kg]			Bar Codes
	Diameter [mm]	Length [mm]	Box	Outer	Pallet	Box	Outer	Pallet		
R-FF1-N-10K080/DT ₁₎	9.8	7	89	50	400	9600	1.73	13.8	362.0	5906675023472
R-FF1-N-10K100/DT ₁₎	9.8	7	109	25	400	9600	1.03	16.5	427.1	5906675023489
R-FF1-N-10K120/DT ₁₎	9.8	7	129	25	300	7200	1.21	14.5	377.9	5906675023496
R-FF1-N-10K140/DT ₁₎	9.8	7	149	25	300	7200	1.37	16.5	425.7	5906675023502

Product commercial data

Product Code	Plug	Screw		Quantity [pcs]			Weight [kg]			Bar Codes
	Diameter [mm]	Length [mm]	Box	Outer	Pallet	Box	Outer	Pallet		
R-FF1-N-10K160/DT 1)	9.8	7	169	25	300	7200	1.54	18.5	472.9	5906675023519
R-FF1-N-10K200/DT 1)	9.8	7	209	25	25	6000	1.91	1.91	487.9	5906675039091
R-FF1-N-10K240/DT 1)	9.8	7	249	25	25	3000	2.2	2.2	298.4	5906675039107
R-FF1-N-10K300/DT 1)	9.8	7	309	10	10	3120	1.08	1.08	365.4	5906675039114

1) ETA-12/0398